

LOC	DIST	REVISIONS				
		REV	DESCRIPTION	DATE	DWN	APP
AJ	17	0	PER EC 0514-0072-05	22APR2005	AF	JL

⚠ USE WITH PRO-CRIMPER 354940-1.
 2. SEE INSTRUCTION SHEET 408-9778.

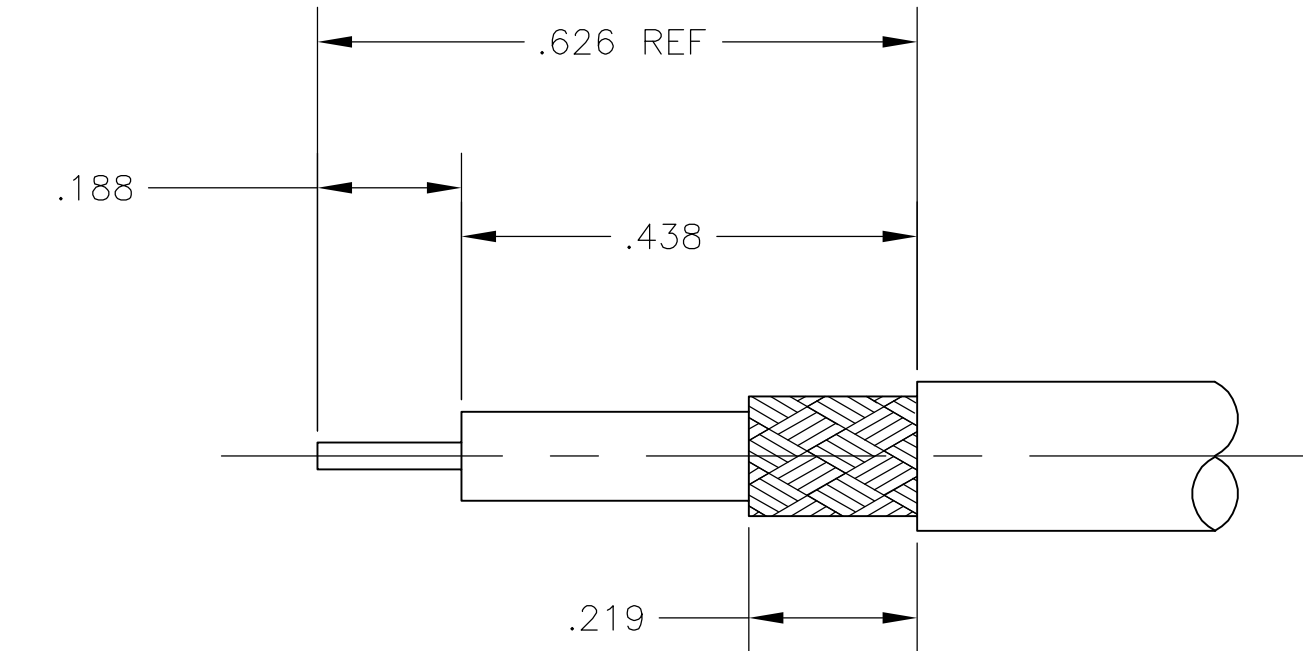
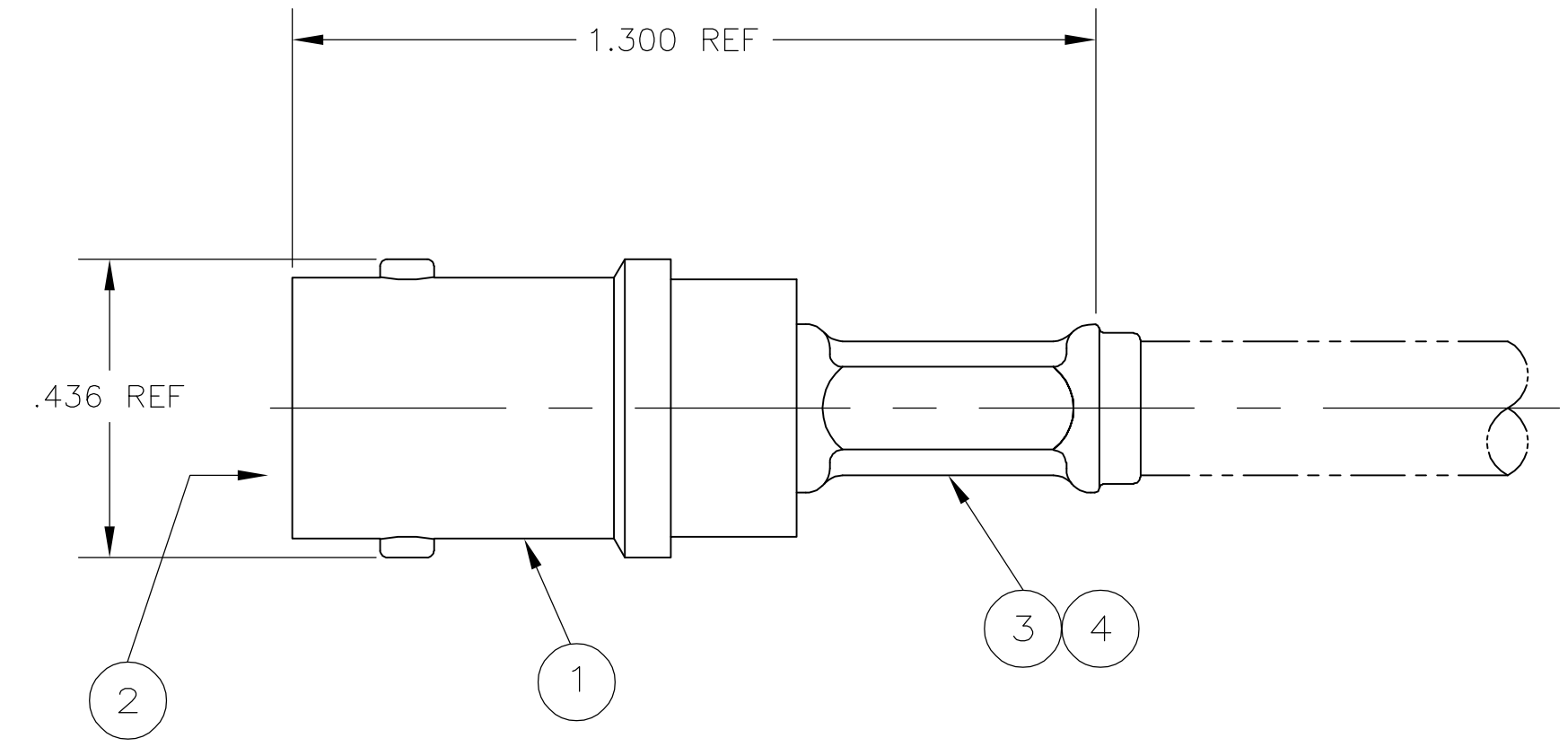

RECOMMENDED STRIP LENGTH

RG-179/U, 179A/U, 179B/U, 187/U & 187A/U	.068	.178	58436-3	21427-2	9-413658-0	2-413774-0	413780-3	5413779-4
RG-174/U, 188/U & 316/U	.068	.178	58436-3	21427-2	9-413658-0	1-413774-5	413780-3	5413779-3
FOR USE WITH CABLE	CONTACT CRIMP (HEX)	FERRULE CRIMP	DIE SET ⚠	④ TUBING QTY=1	③ FERRULE QTY=1	② CONTACT QTY=1	① JACK ASSEMBLY QTY=1	PART NUMBER

THIS DRAWING IS A CONTROLLED DOCUMENT.

DWN	A. FERNANDEZ-DOCKES	22APR2005		Tyco Electronics Corporation
CHK	J. HAVENER	22APR2005		Harrisburg, Pa 17105-3608
APP'D	J. LIPPERT	22APR2005	NAME	JACK, HEX CRIMP, COMMERCIAL BNC
DIMENSIONS: INCHES			TOLERANCES UNLESS OTHERWISE SPECIFIED:	RESTRICTED TO
0	PLC	± .005	PRODUCT SPEC	SIZE: A1 CAGE CODE: 00779 DRAWING NO: 5413779 WEIGHT: -
1	PLC	± .005	APPLICATION SPEC	
2	PLC	± .005	APPROVAL	CUSTOMER DRAWING SCALE: 4:1 SHEET 1 OF 1 REV 0
3	PLC	± .005	FINISH	